



# INSTRUCTION MANUAL

## VCC-6585P E

### COLOR CCD camera

#### About this manual

Before installing and using the camera, please read this manual carefully. Be sure to keep it handy for later reference.

#### ● Dimensions

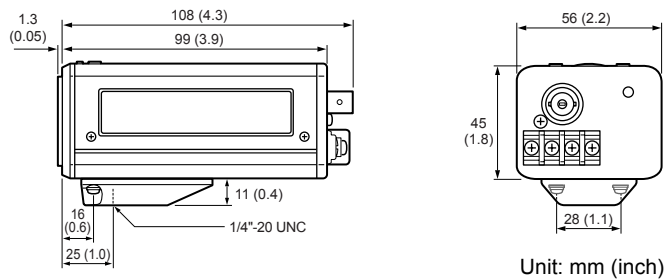

Depending on the conditions of use, installation and environment, please be sure to make the appropriate settings and adjustments. If you need help with installation and/or settings, please consult your dealer.

## FEATURES

- **Backlight compensation:**  
Multi-spot metering (normal and high) and center-weighted metering
- 1/3-inch CCD solid-state image device
- **Number of total pixels: 470,000 pixels**
- **Horizontal resolution of 540 TV lines, Image S/N ratio of 48 dB min.**
- **Minimum required illumination of 0.5 lx (F1.2 lens)**
- **Power supply: AC 24 V and DC 12 V**

#### For EU Users

Your SANYO product is designed and manufactured with high quality materials and components which can be recycled and reused. This symbol means that electrical and electronic equipment, at their end-of-life, should be disposed of separately from your household waste. Please dispose of this equipment at your local community waste collection/recycling centre. In the European Union there are separate collection systems for used electrical and electronic products. Please help us to conserve the environment we live in!

**SANYO FISHER Sales (Europe) GmbH**  
Stahlgruberring 4, D-81829 München, Germany  
**SANYO Electric Co., Ltd.**  
1-1, Sanyo-cho, Daito City, Osaka 574-8534, Japan

#### For Russian Users

This product certified by official certification company which is authorized by Russian Federation.  
**ДЛЯ ПОЛЬЗОВАТЕЛЕЙ РОССИИ**  
Данная продукция сертифицирована официальным органом по сертификации Российской Федерации.

## PRECAUTIONS

#### ■ In case of problem

Do not use the unit if smoke or a strange odor comes from the unit, or if it seems not to function correctly. Turn off the power immediately and disconnect the power cord, and then consult your dealer or an Authorized Sanyo Service Center.

#### ■ Do not open or modify

Do not open the cabinet, as it may be dangerous and cause damage to the unit. For repairs, consult your dealer or an Authorized Sanyo Service Center.

#### ■ Do not put objects inside the unit

Make sure that no metal objects or flammable substance get inside the unit. If used with a foreign object inside, it could cause a fire, a short-circuit or damage. Be careful to protect the unit from rain, sea water, etc. If water or liquid gets inside the unit, turn off the power immediately and disconnect the power cord, and then consult your dealer or an Authorized Sanyo Service Center.

#### ■ Be careful when handling the unit

To prevent damage, do not drop the unit or subject it to strong shock or vibration.

#### ■ Do not install this unit close to magnetic fields

The magnetic fields may result in unstable operation.

#### ■ Protect from humidity and dust

To prevent damage, do not install the unit where there is greasy smoke or steam, where the humidity may get too high, or where there is a lot of dust.

#### ■ Protect from high temperatures

Do not install close to stoves, or other heat sources, such as spotlights, etc., or where it could be subject to direct sunlight, as this could cause deformation, discoloration or other damages. Be careful when installing close to the ceiling, in a kitchen or boiler room, as the temperature may rise to high levels.

#### ■ Cleaning

- Dirt can be removed from the cabinet by wiping it with a soft cloth. To remove stains, wipe with a soft cloth moistened with a soft detergent solution and wrung dry, then dry by wiping with a soft cloth.
- Do not use benzene, thinner or other chemical products on the cabinet, as this may cause deformation and paint peeling. Before using a chemical cloth, make sure to read all accompanying instructions. Make sure that no plastic or rubber material comes into contact with the cabinet for a long period of time, as this may cause damage or paint peeling.



1AC6P1P2814-B  
L5AX2/XE (1207KP-HS)



**SANYO Electric Co., Ltd.**  
Printed in China

## NAMES AND FUNCTIONS OF PARTS

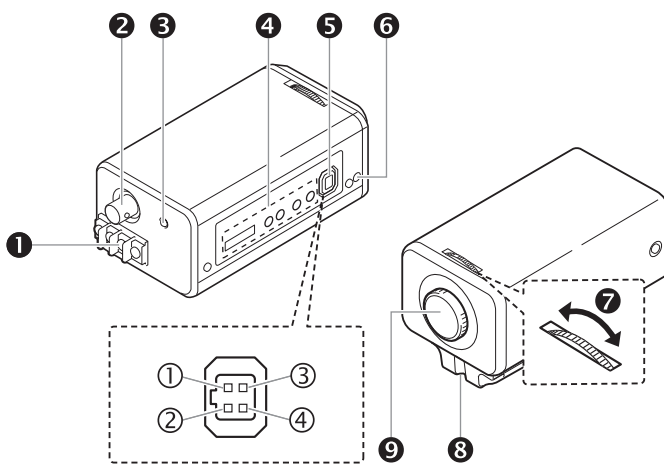

**1 GND terminal, AC24V / DC12V terminal**  
Ground terminal and power input terminal.

**2 VIDEO OUT terminal (BNC connector)**  
Output terminal for connecting to the video input terminal on the monitor, digital video recorder or time-lapse VCR.

**3 POWER indicator**  
Lights when the camera power is on.

**4 Camera adjustment/setting section**  
See "CAMERA ADJUSTMENTS/SETTINGS".

**5 LENS terminal**  
Lens iris output terminal which is used to connect the lens plug when the auto-iris lens is attached.  
① Brake coil (-) ② Brake coil (+)  
③ Drive coil (+) ④ Drive coil (-)

**6 LOCK screw**  
Locking screw for the flange-back adjustment dial.

**7 Flange-back adjustment dial**

**8 Camera attachment bracket**  
Used to attach the camera.

**9 Lens mount cap**  
Protects internal parts of the camera, such as the CCD, from damage.

**● Attaching the lens**  
Use a DC type auto-iris lens (sold separately).

#### NOTE:

- Do not use a lens if length "L" is more than 5 mm (0.2 in.). Otherwise, it may damage the camera and prevent proper installation.
- Depending on the type of lens, the shape of the lens plug may differ. In this case, consult your dealer or an Authorized Sanyo Service Center.
- When attaching a C mount lens, attach the lens to the camera after inserting the C mount ring (sold separately).

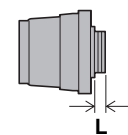

- 1 Remove the lens mount cap from the camera.
- 2 Install the auto-iris lens.
- 3 Connect the lens plug to the LENS terminal on the side of the camera.

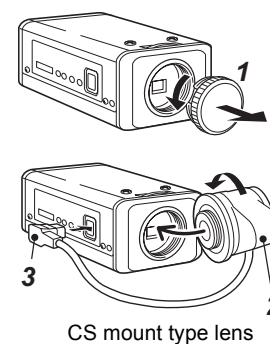

## TROUBLESHOOTING

Before sending the camera out for repair, check the items below. If the problem persists after checking these items, consult your dealer or an Authorized Sanyo Service Center.

#### ■ If no image appears

- Is the coaxial cable attached securely?
- Are the power and voltage normal?
- Has the iris of the lens been adjusted correctly (with the LEVEL dial)?
- Is there adequate illumination?

#### ■ If the image is unclear

- Is the monitor adjusted correctly?
- Is the flange-back position correctly set?
- Is the lens in focus?
- Is the lens clean?  
Dirt or fingerprints on the lens can adversely affect the image. Gently wipe any dirt or fingerprints off the lens with a soft cloth or lens cleaning paper and cleaning fluid (commercially available).

## SERVICE

The camera is a precision instrument. Handle it carefully and always follow the safety precautions. If the camera requires service, never try to repair it yourself or open the casing.

For servicing, maintenance, or repairs, consult your dealer or an Authorized Sanyo Service Center.

## SPECIFICATIONS

Scanning system	: PAL standard TV system (625 TV lines, 25 frames/s)
Interface	: 2:1 interlace
Image device	: Interline transfer method, 1/3-inch solid-state image device CCD
Number of effective pixels	: 752 (H) x 582 (V)
Sync system	: Internal sync/Line lock (only when using an AC 24 V adapter)
Horizontal resolution	: 540 TV lines, typical
Video output terminal	: 1.0 V(p-p)/75 Ω, BNC, composite
Image S/N ratio	: More than 48 dB (More than 50 dB for AGC OFF)
Minimum required illumination (incandescent lighting)	: GAIN HI: Approx. 0.5 lx (F 1.2 lens) GAIN NORM: Approx. 1.0 lx (F 1.2 lens)
Backlight compensation	: OFF/Multi-spot metering (2 modes)/Center-weighted metering
Iris function	: Auto-iris/Electronic-iris
Lens iris output terminal	: 4-pin
Flange-back	: 12.5 mm ±0.5 mm/0.5 in. ±0.02 in.
White balance	: Auto-tracing white balance/Manual
Gain control	: Normal/High
Lens mount	: CS mount
Operating environment	: Temperature: -10°C – +50°C (14°F – 122°F) Humidity: less than 90%RH (no condensation)
Power supply	: AC 24 V ±10%, 50 Hz/DC 12 – 15 V
Power consumption	: 3.6 W (with auto-iris lens)
Weight	: Approx. 280 g/9.0 oz. (without lens)

Appearance and specifications are subject to change without prior notice or obligations.

# CONNECTIONS AND INSTALLATION

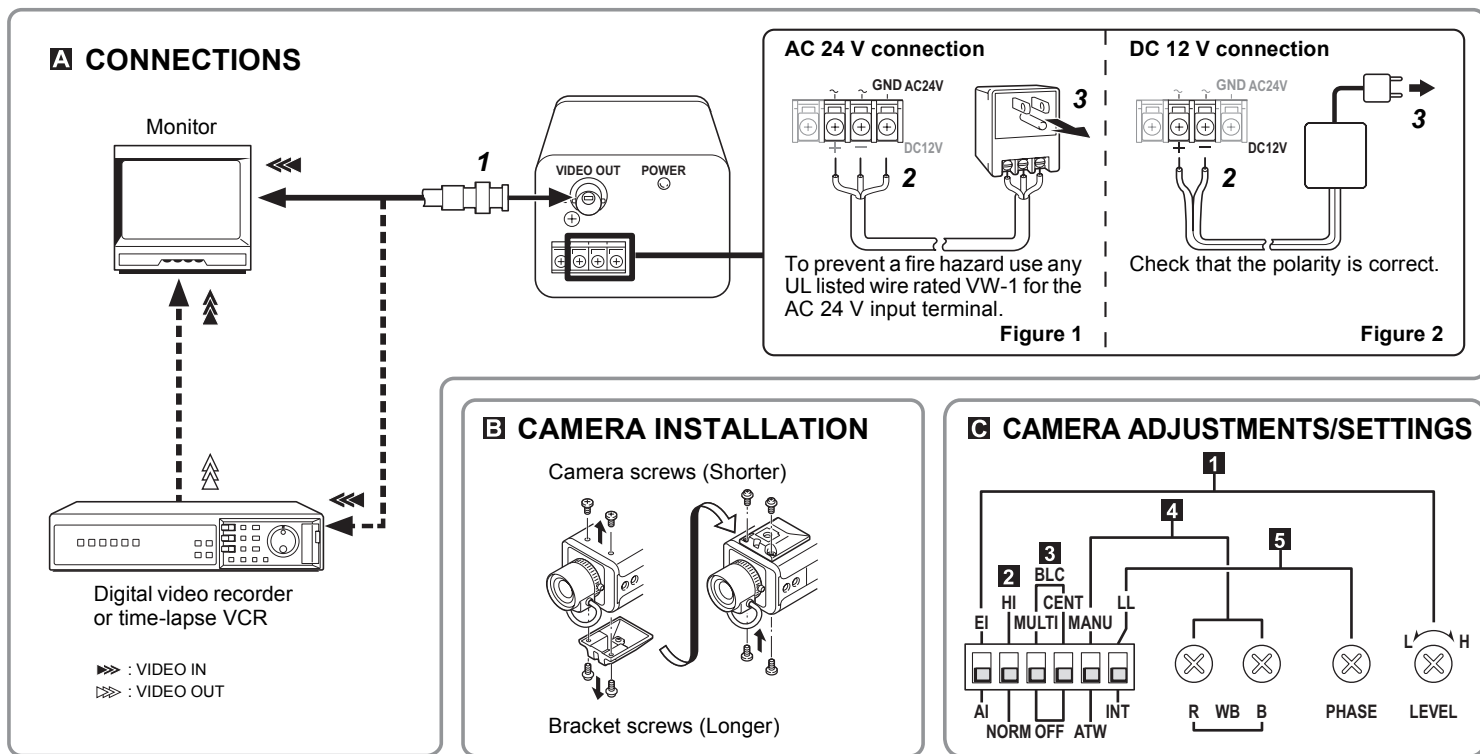

## A CONNECTIONS

### What you need

- Peripheral equipment (such as monitor, digital video recorder or time-lapse VCR)
- Cables for connecting peripheral equipment and camera (coaxial cables, connecting plugs)
- Power adapter (AC 24 V or DC 12 V)

### Supported coaxial cables

- You can use any of the following coaxial cables:
- RG-59U (3C-2V) Length: 250 m/273 yds max.
  - RG-6U (5C-2V) Length: 500 m/547 yds max.
  - RG-11U (7C-2V) Length: 600 m/656 yds max.

### CAUTION

- When using an RG-59U (3C-2V) cable, do not use it on piping or air wiring.
- Select the cable according to the distance between the devices you wish to connect.
- If you use a cable other than the types above, the image or sync signal will be attenuated and will not be transmitted correctly.

### Making connections

1 Connect the camera and peripheral equipment.

2 Connect the power cable.

<When using an AC 24 V adapter>

Connect 3 wire grounded cable (18AWG or higher) as shown in Figure 1.

<When using a DC 12 V adapter>

Connect the cable as shown in Figure 2.

3 Insert the power adapter plug into the wall outlet.

The POWER indicator (red) lights.

## B CAMERA INSTALLATION

### Camera attachment bracket

The camera attachment bracket can be reconfigured as shown in Figure "B CAMERA INSTALLATION" above depending on the installation environment. As per design, use the removed screws.

### NOTE:

- When monitoring lighting or other extremely bright objects (which exceed the maximum required illumination), smearing may occur in the vertical or horizontal direction (either above and below the high-brightness object or as a perpendicular band). In such a case, adjust the angle of illumination and other factors while observing the monitor.
- When using the camera attachment stand (sold separately), select a location that will be able to withstand the weight of the camera and stand for many years, and fix them securely in place.

### Flange-back adjustment

This normally does not need adjustment. If the picture is out of focus at the telephoto position, adjust the flange-back position as described below.

1 Loosen the LOCK screw.

2 Set to the maximum telephoto position and focus the picture using the focus ring.

3 Set to the maximum wide-angle position and focus the picture using the flange-back adjustment dial.

Repeat steps 2 and 3 if the image does not stay in focus when changing from a wide-angle shot to a telephoto shot.

4 When the setting is complete, tighten the LOCK screw.

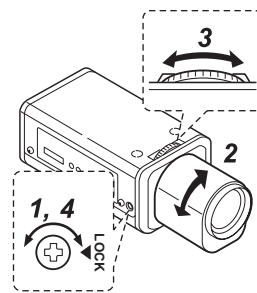

# ADJUSTMENTS AND SETTINGS

## C CAMERA ADJUSTMENTS/SETTINGS

The camera comes pre-adjusted and ready to install at time of factory shipment, but you may want to make adjustments or settings to adapt to the operating conditions or installation environment. If you have trouble adjusting the camera, consult your dealer or an Authorized Sanyo Service Center. (◆ = Factory default setting)

### 1 Iris setting

Change iris setting when using either lens below.

EI	(for indoor use) When using a manual or fixed iris lens and the electronic iris function is on. • Set the lens aperture to the shortest F stop.
AI ◆	When using an auto-iris lens. If the entire image is too dark or too bright, adjust the contrast using the LEVEL dial. • L (Counterclockwise): Closes the lens iris, making the entire image darker. • H (Clockwise): Opens the lens iris, making the entire image brighter.

### NOTE on EI setting:

- If fluorescent lighting is used where the camera is installed, the object will flicker as a result. This type of phenomenon can be avoided by replacing the fluorescent lighting with incandescent lamps.
- If the light entering the lens exceeds the maximum required illumination, the image cannot be displayed properly. In that case, manually adjust the lens iris.

### 2 Gain control

For adjusting the sensitivity of the camera. Use this setting for shooting in dark environments.

HI	Increased sensitivity allows shots to be taken in dark environments.
NORM ◆	Normal setting

### NOTE:

The HI setting causes noise generation and a grainy image.

### 3 BLC: Backlight compensation

This camera has three different backlight compensation modes. Change the mode to match the backlight condition.

	Multi-spot metering, normal mode: When applying backlight compensation to the entire screen.	3
	Multi-spot metering, high mode: When applying more backlight compensation than normal mode.	3
	Center-weighted metering mode: When applying backlight compensation to only the central portion of the screen.	3
OFF ◆	This function is off.	3

### NOTE on multi-spot metering:

If the background of the object is extremely dark, set to "Center-weighted metering mode."

## 4 WB: White balance (color compensation)

MANU	Lets you fine-tune the white balance manually.	
	WB	• R (Red) dial : Turn clockwise to augment screen red. • B (Blue) dial : Turn clockwise to augment screen blue.
ATW ◆	Compensation is performed automatically.	

## 5 Sync setting

(Only when using an AC 24 V adapter)

LL	Line-Lock: Synchronizes the unit with power frequency when two or more cameras are connected via a switcher unit. When the image on the monitor rolls vertically, adjust the phase. • If using this unit as the second or subsequent camera; Adjust the roll by turning the PHASE dial.
	• If using this unit as the first camera; Adjust the roll using the phase adjuster on the second and subsequent cameras.
INT ◆	Internal sync

### NOTE:

When using a DC 12 V adapter, the sync setting is set to Internal sync.